

LM25007 Evaluation Board

National Semiconductor
Application Note 1453
Dennis Morgan
March 2006



Introduction

The LM25007EVAL evaluation board provides the design engineer with a fully functional buck regulator, employing the constant on-time (COT) operating principle. This evaluation board provides a 5V output over an input range of 9V - 42V. The circuit delivers load currents to 450 mA, with current limit at ≈ 670 mA. The board is populated with all external components except C6 and C9. These components provide options for managing the output ripple as described later in this document.

The board's specification are:

- Input Voltage: 9V to 42V
- Output Voltage: 5V
- Maximum load current: 450 mA
- Minimum load current: 0 mA
- Current Limit: ≈ 670 mA
- Measured Efficiency: 92.6% ($V_{IN} = 9V$, $I_{OUT} = 150$ mA)
- Nominal Switching Frequency: 306 kHz
- Size: 1.6 in. x 1.0 in. x 0.5 in

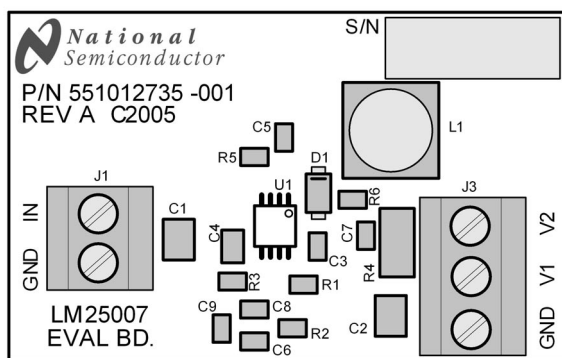

20185001

FIGURE 1. Evaluation Board - Top Side

Theory of Operation

Refer to the evaluation board schematic in Figure 5, which contains a simplified block diagram of the LM25007. When the circuit is in regulation, the buck switch is on each cycle for a time determined by R1 and the input voltage according to the equation:

$$t_{ON} = \frac{1.42 \times 10^{-10} \times R1}{V_{IN}}$$

The nominal switching frequency is calculated from:

$$F_S = \frac{V_{OUT}}{1.42 \times 10^{-10} \times R1}$$

The on-time in this evaluation board ranges from ≈ 1800 ns at $V_{IN} = 9V$, to ≈ 390 ns at $V_{IN} = 42V$. The on-time varies inversely with V_{IN} to maintain a nearly constant switching frequency, which is nominally 306 kHz in this evaluation board. At the end of each on-time the Minimum Off-Timer ensures the buck switch is off for at least 300 ns. In normal operation the off-time is much longer. During the off-time the output capacitor (C2) is discharged by the load current. When the output voltage falls sufficiently that the voltage at FB is below 2.5V, the regulation comparator initiates a new

on-time period. For stable, fixed frequency operation, ≈ 25 mVp-p of ripple is required at FB to switch the regulation comparator. Refer to the LM25007 data sheet for a more detailed block diagram, and a complete description of the various functional blocks.

Board Layout and Probing

The pictorial in Figure 1 shows the placement of the circuit components. The following should be kept in mind when the board is powered:

- 1) When operating at high input voltage and high load current, forced air flow is recommended.
- 2) The LM25007 may be hot to the touch when operating at high input voltage and high load current.
- 3) Use CAUTION when probing the circuit at high input voltages to prevent injury, as well as possible damage to the circuit.
- 4) Ensure the wires connecting this board to the load are sized appropriately for the load current. Ensure there is not a significant drop in the wires between this evaluation board and the load.

Board Connection/Start-up

The input connections are made to the J1 connector. The load is normally connected to the V1 and GND terminals of the J3 connector. Ensure the wires are adequately sized for

Board Connection/Start-up (Continued)

the intended load current. Before start-up a voltmeter should be connected to the input terminals, and to the output terminals. The load current should be monitored with an ammeter or a current probe. It is recommended that the input voltage be increased gradually to 9V, at which time the output voltage should be 5V. If the output voltage is correct with 9V at V_{IN} , then increase the input voltage as desired and proceed with evaluating the circuit.

Output Ripple Control

The LM25007 requires a minimum of 25 mVp-p ripple at the FB pin, in phase with the switching waveform at the SW pin, for proper operation. In the simplest configuration that ripple is derived from the ripple at V_{OUT1} , generated by the inductor's ripple current flowing through R4. That ripple voltage is attenuated by the feedback resistors, requiring that the ripple amplitude at V_{OUT1} be higher than the minimum of 25 mVp-p by the gain factor. Options for reducing the output ripple are discussed below, and the results are shown in the graph of Figure 8.

A) **Minimum Output Ripple:** This evaluation board is supplied configured for minimum ripple at V_{OUT1} by setting R4 to zero ohms, and including components R6, C7 and C8. The output ripple, which ranges from 2 mVp-p at $V_{IN} = 9V$ to 7 mVp-p at $V_{IN} = 42V$, is determined primarily by the ESR of output capacitor (C2), and the inductor's ripple current, which ranges from 75 mAp-p to 144 mAp-p over the input voltage range. This performance applies only to continuous conduction mode as the ripple amplitude is higher in discontinuous conduction mode. The ripple voltage required by the FB pin is generated by R6, C7 and C8 since the SW pin

switches from -1V to V_{IN} , and the right end of C7 is a virtual ground. The values for R6 and C7 are chosen to generate a 30-40 mVp-p triangle waveform at their junction. That triangle wave is then coupled to the FB pin through C8. The following procedure is used to calculate values for R6, C7 and C8:

1) Calculate the voltage V_A :

$$V_A = V_{OUT} - (V_{SW} \times (1 - (V_{OUT}/V_{IN})))$$

where V_{SW} is the absolute value of the voltage at the SW pin during the off-time (typically 1V), and V_{IN} is the minimum input voltage. For this circuit V_A calculates to 4.55V. This is the DC voltage at the R6/C7 junction, and is used in the next equation.

2) Calculate the R6 x C7 product:

$$R6 \times C7 = \frac{(V_{IN} - V_A) \times t_{ON}}{\Delta V}$$

where t_{ON} is the maximum on-time (≈ 1800 ns), V_{IN} is the minimum input voltage, and ΔV is the desired ripple amplitude at the R6/C7 junction, 30 mVp-p for this example.

$$R6 \times C7 = \frac{(9V - 4.55V) \times 1800 \text{ ns}}{0.03V} = 2.67 \times 10^{-4}$$

R6 and C7 are then chosen from standard value components to satisfy the above product. For example, C7 can be 2200 pF requiring R6 to be 121 k Ω . C8 is chosen to be 0.01 μ F, large compared to C7. This portion of the circuit, as supplied on this EVB, is shown in Figure 2.

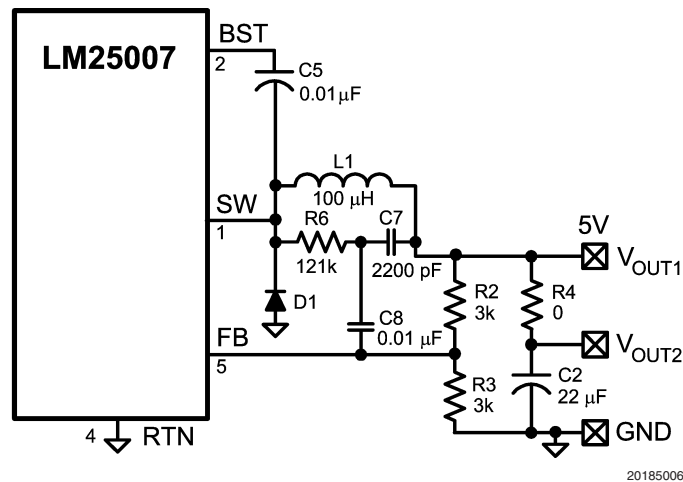

FIGURE 2. Minimum Ripple Using R6, C7, C8

Output Ripple Control (Continued)

B) Intermediate Ripple Level Configuration: This configuration generates more ripple at V_{OUT1} than the above con-

figuration, but uses one less capacitor. If some ripple can be tolerated in the application, this configuration is slightly more economical, and simpler. R4 and C6 are used instead of R6, C7, and C8, as shown in Figure 3.

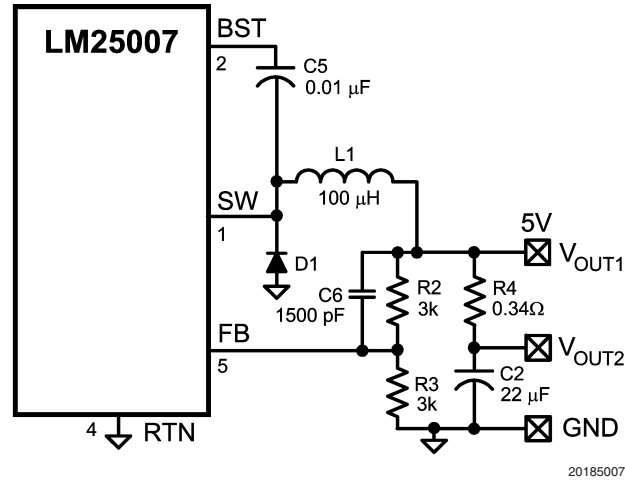

FIGURE 3. Intermediate Ripple Level Configuration Using C6 and R4

R4 is chosen to generate ≥ 25 mV at V_{OUT1} , knowing that the minimum ripple current in this circuit is 75 mA_{p-p} at minimum V_{IN} . C6 couples that ripple to the FB pin without the attenuation of the feedback resistors. C6's minimum value is calculated from:

$$C6 = \frac{t_{ON(max)}}{(R2//R3)}$$

where $t_{ON(max)}$ is the maximum on-time (at minimum V_{IN}), and $R2//R3$ is the equivalent parallel value of the feedback resistors. For this evaluation board $t_{ON(max)}$ is approximately 1800 ns, and $R2//R3 = 1.5$ k Ω , and C6 calculates to a minimum of 1200 pF. The resulting ripple at V_{OUT1} ranges

from ≈ 25 mV_{p-p} to 50 mV_{p-p} over the input voltage range with the circuit in continuous conduction mode. The ripple amplitude is higher if the load current is low enough to force the circuit into discontinuous conduction mode.

C) Minimum Cost Configuration: This configuration is the same as option B above, but without C6. Since 25 mV_{p-p} are required at the FB pin, R4 is chosen to generate 50 mV_{p-p} at V_{OUT1} , knowing that the minimum ripple current in this circuit is 75 mA_{p-p} at minimum V_{IN} . To allow for tolerances, 0.68 Ω is used for R4. The resulting ripple at V_{OUT1} ranges from ≈ 50 mV_{p-p} to ≈ 100 mV_{p-p} over the input voltage range. If the application can accept this ripple level, this is the most economical solution. The circuit is shown in Figure 4.

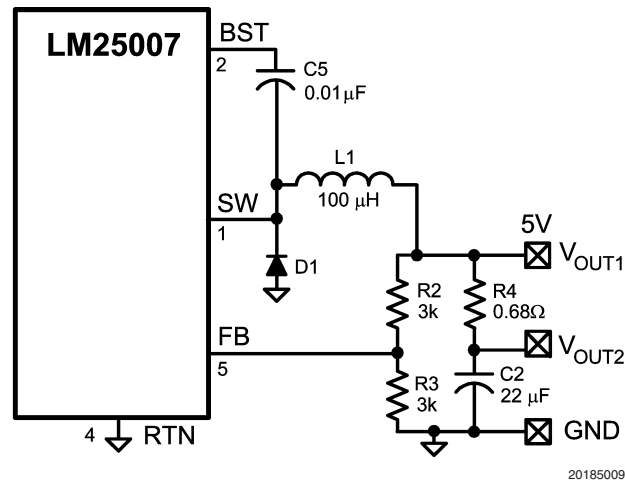

FIGURE 4. Minimum Cost Configuration

Output Ripple Control (Continued)

D) **Alternate Low Ripple Configuration:** A low ripple output can be obtained by connecting the load to V_{OUT2} in the circuits of options B or C above. Since R4 degrades load regulation, this alternative may be viable for applications where the load current is relatively constant. If this method is used, ensure R4's power rating is appropriate for the load current.

Current Limit

The LM25007 contains an intelligent current limit off-timer. The current limit threshold is 725 mA, $\pm 25\%$. If the current in the buck switch (the peak of the inductor's current waveform) reaches the threshold the present on-time cycle is immediately terminated, and a non-resettable off-time is initiated. The length of the off-time is controlled by an external resistor (R5) and the voltage at the FB pin. If $V_{FB} = 0V$ (output is shorted to ground) the off-time is the preset maximum of 17 μs . This off-time ensures safe short circuit operation to the maximum input voltage of 42V. In cases of less severe overload where the output voltage, and the voltage at FB, is above ground the current limit off-time is less than 17 μs . The shorter off-times reduces the amount of foldback, recovery time, and also reduces the startup time. The current limit off-time is calculated from the following equation:

$$t_{OFF} = \frac{10^{-5}}{0.59 + \frac{V_{FB}}{7.22 \times 10^{-6} \times R5}}$$

The current limit off-time ranges from 4.3 μs to 17 μs as V_{FB} varies from 2.5V to 0V, with $R5 = 200 k\Omega$. The guideline for selecting R5's value is that the current limit off-time (at $V_{FB} = 2.5V$) should be slightly longer than the maximum off-time encountered in normal operation. Setting a shorter off-time could result in inadequate overload protection, and setting a much longer off-time can affect the startup operation.

Minimum Load Current

The LM25007 requires a minimum load current of $\approx 500 \mu A$ to ensure the boost capacitor (C5) is recharged sufficiently during each off-time. In this evaluation board, the minimum load current is provided by the feedback resistors (R2, R3), allowing the board's minimum load current to be specified at zero.

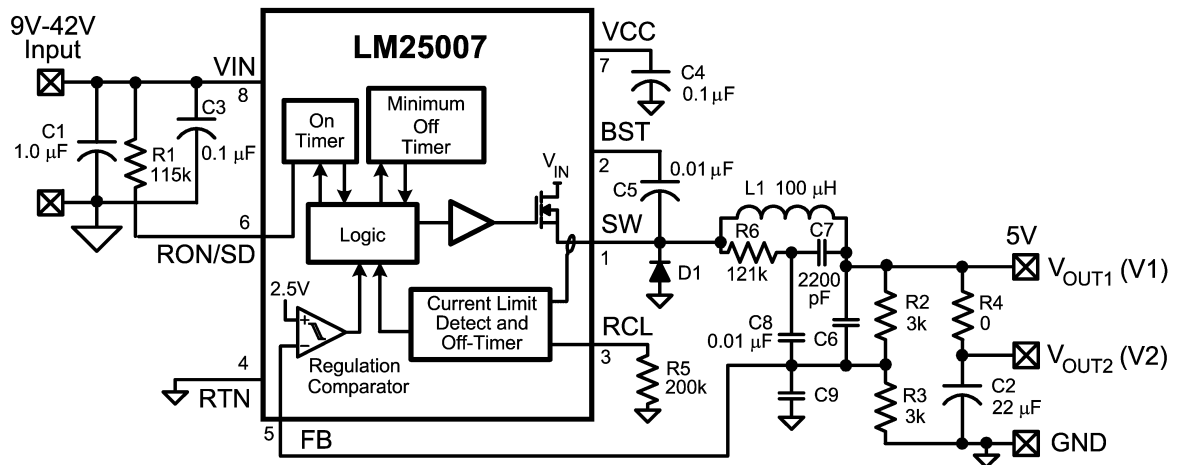

20185011

FIGURE 5. Complete Evaluation Board Schematic

Bill of Materials

Item	Description	Mfg., Part Number	Package	Value
C1	Ceramic Capacitor	TDK C3225X7R2A105M	1210	1.0 μ F, 100V
C2	Ceramic Capacitor	TDK C3225X7R1C226M	1210	22 μ F, 16V
C3, 4	Ceramic Capacitor	TDK C2012X7R2A104M	0805	0.1 μ F, 100V
C5,8	Ceramic Capacitor	TDK C2012X7R2A103M	0805	0.01 μ F, 100V
C6		Unpopulated	0805	
C7	Ceramic Capacitor	TDK C2012X7R2A222M	0805	2200 pF
C9		Unpopulated	0805	
D1	Schottky Diode	Diodes Inc. DFSL160	Power DI 123	60V, 1A
L1	Power Inductor	TDK SLF7045T-101MR50	7 mm x 7 mm	100 μ H
R1	Resistor	Vishay CRCW08051153F	0805	115 k Ω
R2, 3	Resistor	Vishay CRCW08053011F	0805	3.01 k Ω
R4	Resistor	Vishay CRCW2010000Z	2010	0 Ω
R5	Resistor	Vishay CRCW08052003F	0805	200 k Ω
R6	Resistor	Vishay CRCW08051213F	0805	121 k Ω
U1	Switching Regulator	National Semiconductor LM25007MM	MSOP-8	

Circuit Performance

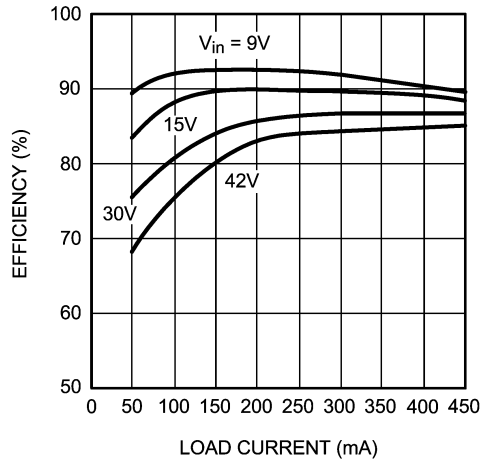

20185012

FIGURE 6. Efficiency vs Load Current

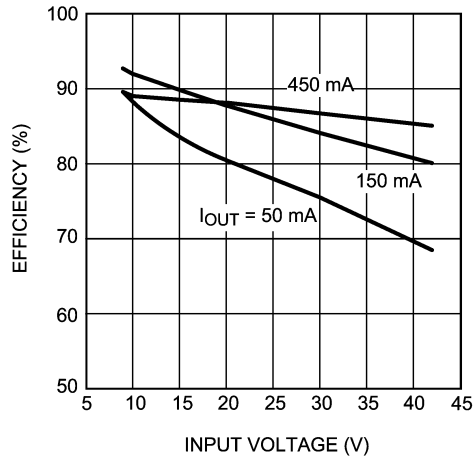

20185013

FIGURE 7. Efficiency vs Input Voltage

Circuit Performance (Continued)

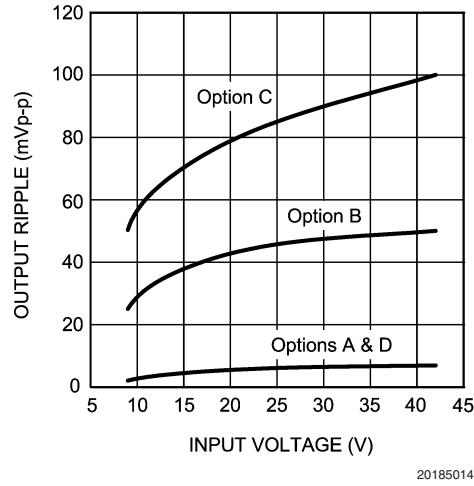

FIGURE 8. Output Voltage Ripple

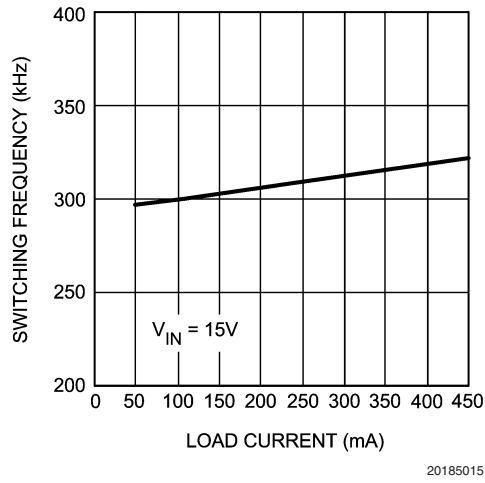
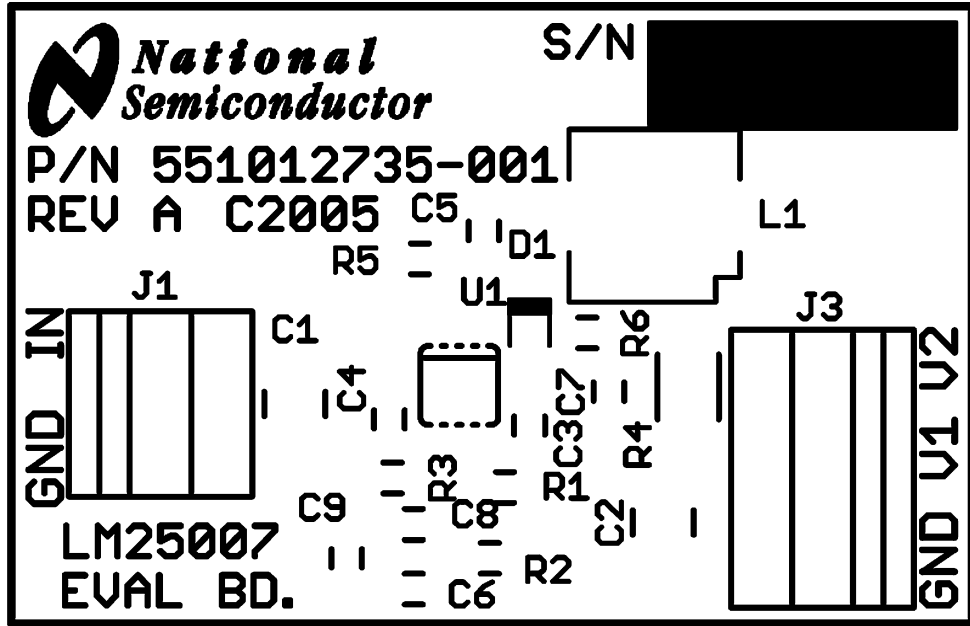

FIGURE 9. Switching Frequency vs. Load Current

PCB Layout



20185016

Board Silkscreen

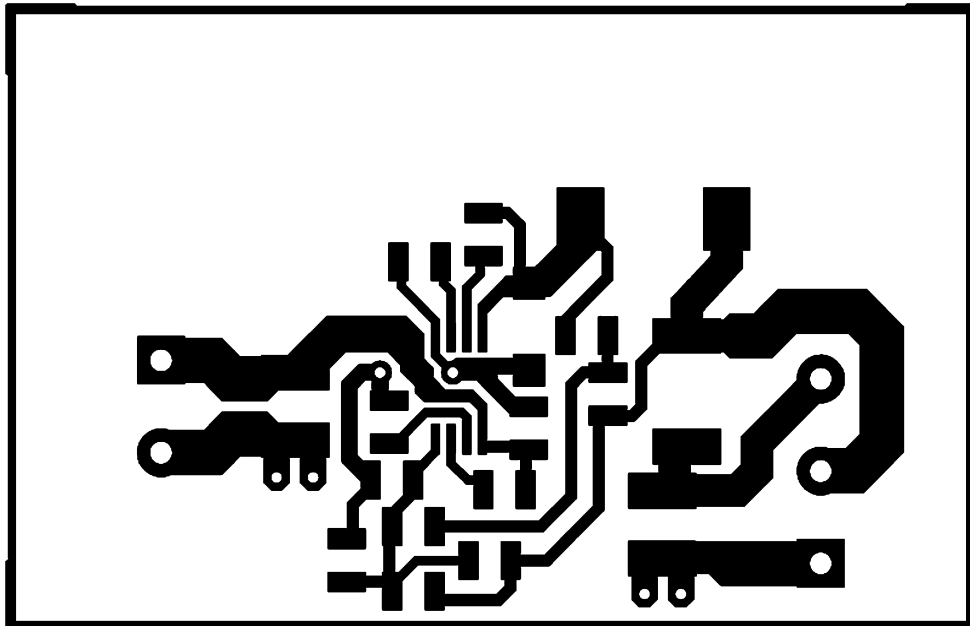

20185017

Board Top Layer

PCB Layout (Continued)

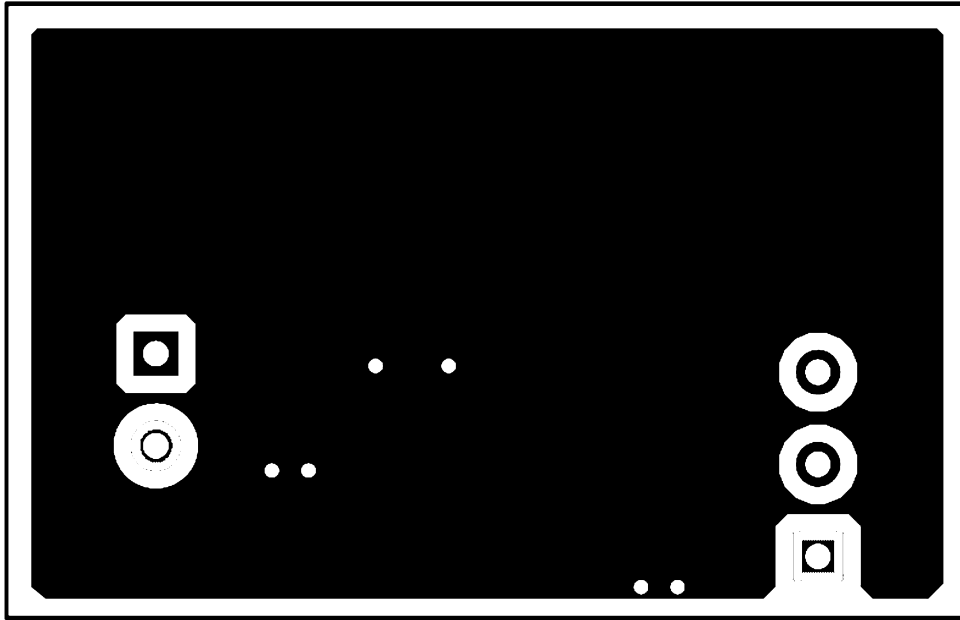

20185018

Board Bottom Layer (viewed from top)

National does not assume any responsibility for use of any circuitry described, no circuit patent licenses are implied and National reserves the right at any time without notice to change said circuitry and specifications.

For the most current product information visit us at www.national.com.

LIFE SUPPORT POLICY

NATIONAL'S PRODUCTS ARE NOT AUTHORIZED FOR USE AS CRITICAL COMPONENTS IN LIFE SUPPORT DEVICES OR SYSTEMS WITHOUT THE EXPRESS WRITTEN APPROVAL OF THE PRESIDENT AND GENERAL COUNSEL OF NATIONAL SEMICONDUCTOR CORPORATION. As used herein:

1. Life support devices or systems are devices or systems which, (a) are intended for surgical implant into the body, or (b) support or sustain life, and whose failure to perform when properly used in accordance with instructions for use provided in the labeling, can be reasonably expected to result in a significant injury to the user.
2. A critical component is any component of a life support device or system whose failure to perform can be reasonably expected to cause the failure of the life support device or system, or to affect its safety or effectiveness.

BANNED SUBSTANCE COMPLIANCE

National Semiconductor manufactures products and uses packing materials that meet the provisions of the Customer Products Stewardship Specification (CSP-9-111C2) and the Banned Substances and Materials of Interest Specification (CSP-9-111S2) and contain no "Banned Substances" as defined in CSP-9-111S2.

Leadfree products are RoHS compliant.



National Semiconductor
Americas Customer
Support Center
Email: new.feedback@nsc.com
Tel: 1-800-272-9959

National Semiconductor
Europe Customer Support Center
Fax: +49 (0) 180-530 85 86
Email: europe.support@nsc.com
Deutsch Tel: +49 (0) 69 9508 6208
English Tel: +44 (0) 870 24 0 2171
Français Tel: +33 (0) 1 41 91 8790

National Semiconductor
Asia Pacific Customer
Support Center
Email: ap.support@nsc.com

National Semiconductor
Japan Customer Support Center
Fax: 81-3-5639-7507
Email: jpn.feedback@nsc.com
Tel: 81-3-5639-7560

www.national.com